



DUAL PLATE Check Valve

Series : SI - 1023

S.I. (SI-1023) Series Dual Plate Check Valves are manufactured in a wide variety of required specifications, Temperature / Pressure Rating & different design features to meet specific requirement of Non return Flow application in the waterline, Oil Field, Steam & Gas Line, etc.

DESIGN FEATURES

Which makes cost efficient and product reliability of S.I. Dual Plate Check Valve

UNIT COST : Through simplicity of design, together with compact wafer styling and utilization of high tensile strength material, a low initial cost is achieved.

OPERATING COST : Careful attention to inlet contouring, streamlined flow design combined with an expanded flow area, results in unusually low pressure loss characteristics.

The resulting low power consumption translates into money savings throughout the long life of the valve.

PRODUCT RELIABILITY : The use of design features such as Lift & Pivot Action, Disc Seal Overlap, Pressure Sensitive Seating, Stabilization Spheres, Disc Stabilization and Flow Sensitive Closure, together with careful selection of materials of construction, reflect company's efforts to build a Quality Product.

CONSTRUCTION FEATURES

Check Valve Body available in Cast Gun-Metal / Cast Iron / Cast Carbon Steel / Stainless Steel with Cast Gun-Metal / Ductile Iron / Stainless Steel / Cast Carbon Steel Disc.

AVAILABLE SIZES

Check Valves are available from 50mm upto 400mm.

QUALITY CONTROL

All the Raw Material used in the construction of these Check Valves are produced from highest quality material and subject to stringent quality control. Each and every Valve is Pressure tested prior to leaving factory.



PIC-1

MATERIAL OF CONSTRUCTION

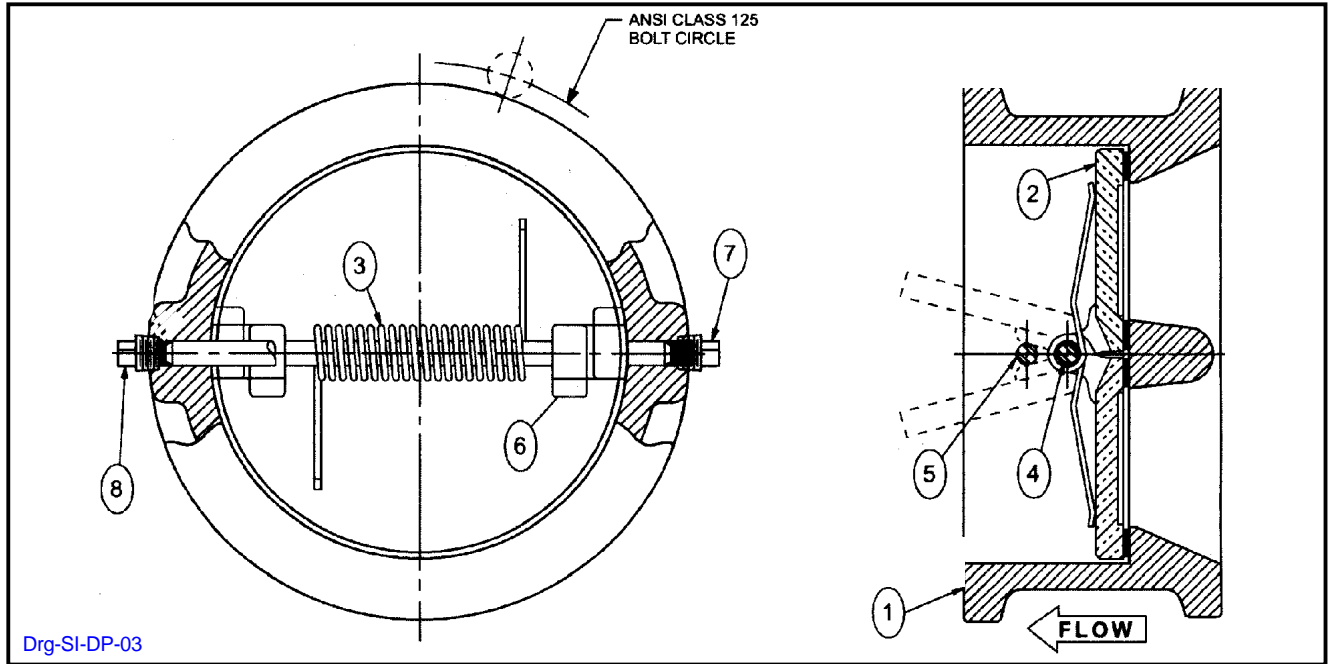

1. Body

Compact Wafer Style reduces installation time, minimizes space required for installation, and results in low initial unit cost.

2. Disc

Dual Plate Design increases valve sensitivity to flow, allowing closure before flow reversal.

3. Spring

Specially Designed torsion spring closed Discs upon pump shut down, minimizing water Hammer normally associated with valve shut off. Also provides for Lift & Pivot Disc action.

4. Hing Pin

Heavy duty construction with increased bearing surface & Strength.

5. Stop Pin

Positions Discs on slight angle during flow, preventing disc flutter.

6. Thrust Bearings

Reduces Friction & Wear during Disc action.

7. Retainer Plugs

Retains Hinge & Stop Pins & provides compression to stabilization spheres.

8. Rubber Seating

Specially designed pressure sensitive seating with Full Disc overlap, provides positive seating at all pressures.

Check Valve Material Specifications

1	Valve Body (Optional)	:	Cast Gun-Metal / Cast Iron / Cast Carbon Steel / Stainless Steel.
2	Disc (Optional)	:	Cast Gun-Metal / Ductile Iron / Stainless Steel.
3	Spring	:	Stainless Steel - 316.
4	Hing Pin	:	Stainless Steel - 410.
5	Stop Pin	:	Stainless Steel - 410.
6	Thrust Bearing	:	Gun - Metal.
7	Hing Pin Retainer	:	Carbon Steel.
8	Stop Pin Retainer	:	Carbon Steel.
9	Rubber Seating	:	Neoprene / Silicon / Viton.

DESIGN FEATURES

1. Lift & Pivot Disc Action :

This feature, which is designed into the valve to give longer valve life, takes place during the opening & closing cycles. It works by a combination of clearance between the pivot pin & disc hub, and the placement of the legs of the torsion spring. With this placement the disc will always lift first at the pivot on opening and not return until the disc is closed, preventing any wear between disc & seat surface.



2. Disc Stabilization :

When the valve is fully open, the discs are positioned on a slight angle, causing them to press firmly against the stops. The resulting vector forces act to stabilize the disc during flow conditions thereby preventing excessive wear to disc "Flutter".

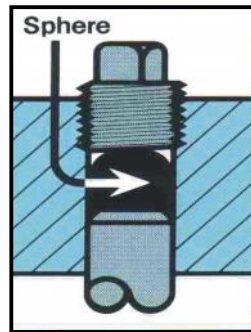

3. Stabilization Spheres :

These hard synthetic spheres, inserted into the pivot & stop pin holes are compressed against the pins and effectively stabilize them during flow conditions, eliminating vibration & wear.

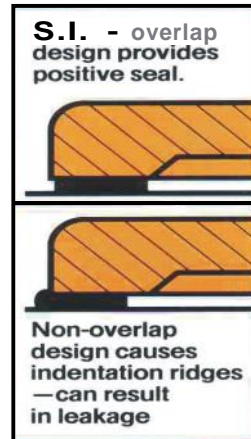

4. Disc Seal Overlap :

Contact between the seal and the disc is uniquely designed to eliminate indentation ridges found in design which do not allow the disc to fully overlap the seal. Indentation ridges caused by valve designs with discs smaller in diameter than the seal can be responsible for valve leakage.

5. Pressure Sensitive Seating :

This design provides for minimum Disc-to-Seat contact at low pressures, and maximum contact at high pressures, resulting in positive seating at all times without seal destruction.

